

ROOF MOUNT KIT OWNERS MANUAL

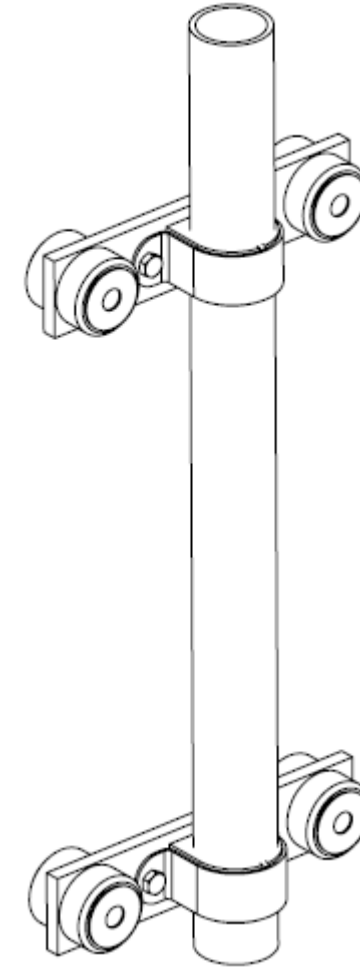

Made in the USA by:
Primus Wind Power, Inc.
938 Quail St.
Lakewood, CO 80215

Phone: (303) 242-5820

www.primuswindpower.com

AIR is a trademark of Primus Wind Power, Inc.

ROOF MOUNT KIT FOR "AIR" WIND TURBINES

This wind turbine roof mount kit is designed to be simple to install and to reduce the vibrations that a wind turbine may produce. It is specifically designed for the mounting of the "AIR" series of wind turbine.

It is important that you read this manual thoroughly before beginning assembly. If you have any questions on proper installation, please call your dealer or Primus Wind Power for more information.

Notice: This information is believed to be reliable, however Primus Wind Power assumes no responsibility for inaccuracies or omissions. The user of this information and product assumes full responsibility and risk. All specifications may be subject to change without notice.

Contents:

Parts List	page 3
Tools Required	page 4
Site Selection	page 5
Pole and Hardware Selection	page 6
Site Preparation	page 7
Pole Mounting	page 7
Attic Mounting	page 8
Mounting Through a Roof	page 9
Wiring and Final Assembly	page 10
Maintenance	page 11
Warranty	page 11
Troubleshooting	page 11

Maintenance

Periodically check to see that all screws and bolts are tight and inspect the rubber isolators for damage. There should be no other maintenance required for this mounting system.

Warranty

Primus Wind Power warrants the Air turbine and roof mount components against any faulty parts or workmanship for three years from the date of purchase. The warranty does not include freight or any incidental costs or damages.

If you have a problem with your AIR or mounting system, first read all relevant portions of the AIR manual and Roof Mount owner's manual. Be sure to observe all safety precautions when diagnosing or removing the turbine. If the turbine or other components are still not operating properly contact your dealer or the factory.

Troubleshooting

If excessive noise is heard or vibration is felt, first check to see that the pole is not able to contact any part of the structure. If the pole extends through a hole in a roof or roof overhang, be sure that the pole is centered in the hole and that the hole is at least 4" (100 mm) in diameter.

If the turbine wires can be heard hitting the inside of the pole, use pipe insulation around the wires inside the pole to eliminate this noise.

If the upper mount is too far below the roof the pole may flex far enough to hit the side of the hole and transmit a great deal of noise and vibration. Enlarging the hole or moving the upper mount up should help alleviate this problem.

If the mounts are attached to a part of the structure that is not solid, the whole section of the structure may vibrate. Moving the mounts to a position directly over a stud or securing 2x4 or 2x6 mounting boards or 12x12x1" plywood mounting blocks to the studs and attaching the mounts to them as outlined in "Site Preparation", on page 7, should help to eliminate this problem.

If the mounts are to be used in very cold weather (below 10 deg. F., -13 deg. C.) you may experience some stiffening of the rubber and additional noise as a result. These isolators are not recommended for temperatures below -50 deg. F (-45 deg. C.).

Secure the roof seal with at least six equally spaced roofing screws or pan head wood screws and washers through the flange of the seal into the roof.

Wiring and Final Assembly

If the top of the pole cannot be reached from the roof of the structure the pole may be slid down to a more accessible height by loosening the mount clamps and rotating the mast while pushing down. Refer to your turbine owner's manual to mount the turbine and wire it to your electrical system properly.

If the turbine is to be mounted to a house or occupied structure where sound suppression must be maximized, it is recommended that the wires be isolated from the inside of the pole. This can be accomplished by installing water pipe insulation around the wires as they are inserted into the pole. Doing this will prevent the turbine wires from rattling against the inside of the pole.

If the pole was lowered to get the turbine onto it, lift and twist the pole until it is at the desired height, then retighten the clamps.

End View of Pole with Wires and Pipe Insulation

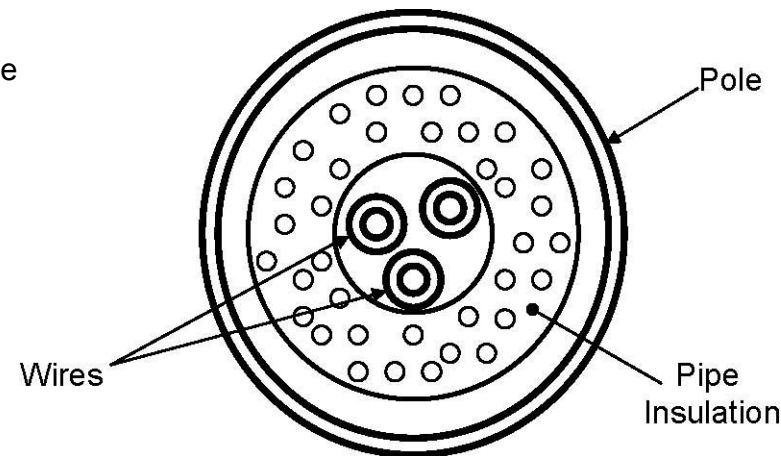

Parts List

Your Roof Mount Kit includes:	Quantity
Isolators	4
Base Plates	2
Clamp Inserts	2
Clamp Straps	2
5/16" x 1" Bolts	4
5/16" Lock Washers	4
5/16" Nuts	4
Optional Roof Seal	1

Please inspect the contents to see that all parts are present and to familiarize yourself with the pieces before beginning assembly.

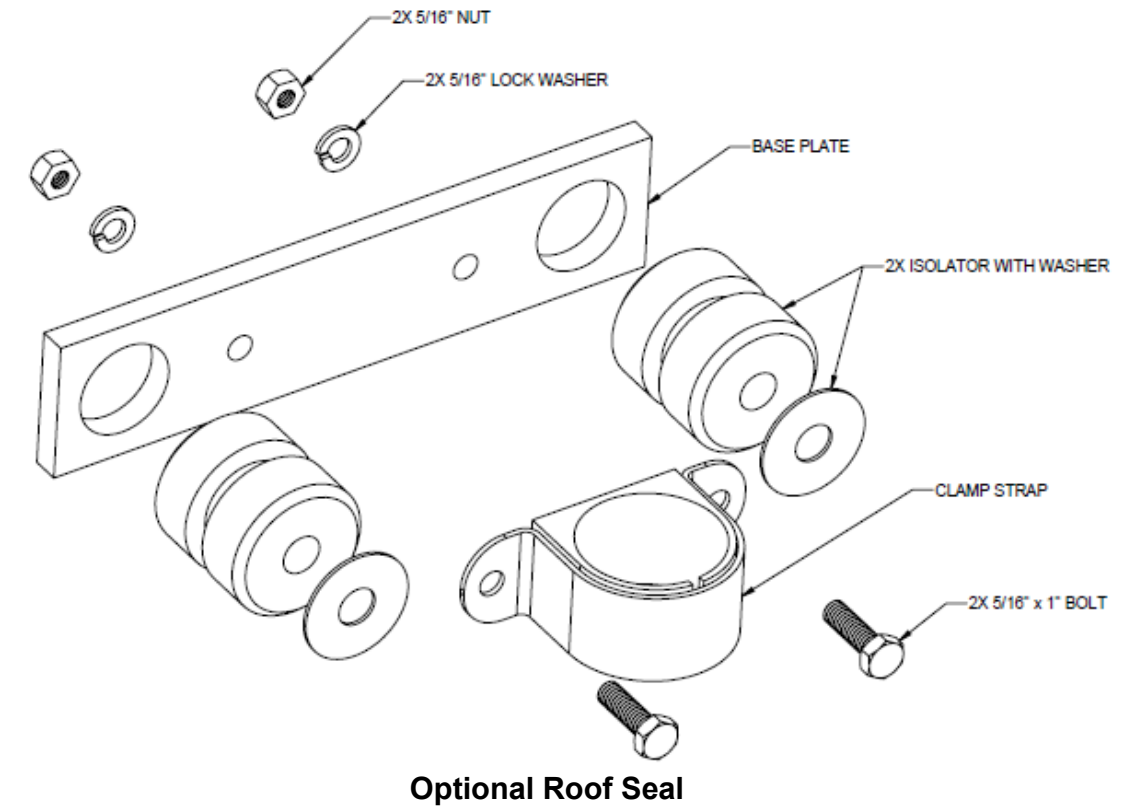

Optional Roof Seal

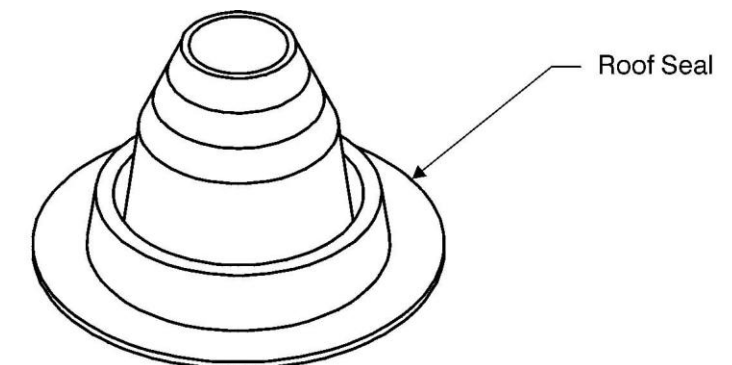

Note: The mounts included in this kit are intended to be attached to the side of building or similar structure. The actual hardware used to mount the kit to the structure may vary, depending on the type of construction and thickness of materials. It is recommended that lag screws or through bolts and washers be used to mount the kit to a wood framed structure. These are not included and should be purchased at your local hardware store. For more information on what hardware to use for your installation please refer to "Pole and hardware selection" on page 6.

Tools Required

Measuring Tape
Pencil
Plumb Bob
Power Drill
3/8" (10mm) Drill Bit
Hacksaw
1/2" or 13mm Wrench
4" (100 mm) diameter hole saw*
Eye Protection

Note: if construction requires the use of special hardware such as nuts, bolts or masonry anchors, other tools may be necessary.

** If the mast is to protrude through the eaves or roof of a house a hole must be made in the roof for this purpose.*

Additional hardware not included in this kit

One 1-7/8" (48mm) Outside diameter, mounting pole (12' (4m) max length) and Four 1/2" X 3-1/2" minimum length lag bolts or 1/2" through bolt with washers

Safe Installation

Safety is the most important consideration to take into account when mounting this kit and wind turbine. It is very important to remember that any wind turbine has high speed spinning parts and can be very dangerous if not installed properly!

The AIR wind turbine must be installed in a place high enough so that a person cannot come in contact with the spinning blades when the turbine is in operation!

If the desired mounting location has a roof or roof overhang in the path of the pole, a hole can be bored through the roof. We offer an optional roof seal, which allows the pole to be sealed to the roof.

Note: When mounting the turbine pole through a hole in a roof it is desirable to mount the upper mount as close to the roof as possible. If the distance from the roof to the upper mount is too great the pole may flex into the side of the hole and cause unacceptable noise.

First determine where the center of the pole will be on the underside of the roof overhang. This can be accomplished by mounting the isolators with the base plates and clamps attached, and using a straight edge or the pole through the mounts to determine where the pole will hit the roof. Mark the center of the hole and bore a 4" (100 mm) diameter hole (with the hole saw) up through the roof from underneath, then trim away any shingles or other roofing material so that the hole is clear of obstructions.

Mount the pole (see section on page 10) and slide the roof seal over it from the top down until it is about six inches (150 mm) from the roof surface. Trim away any excess roofing material so that the seal will be able to sit flat.

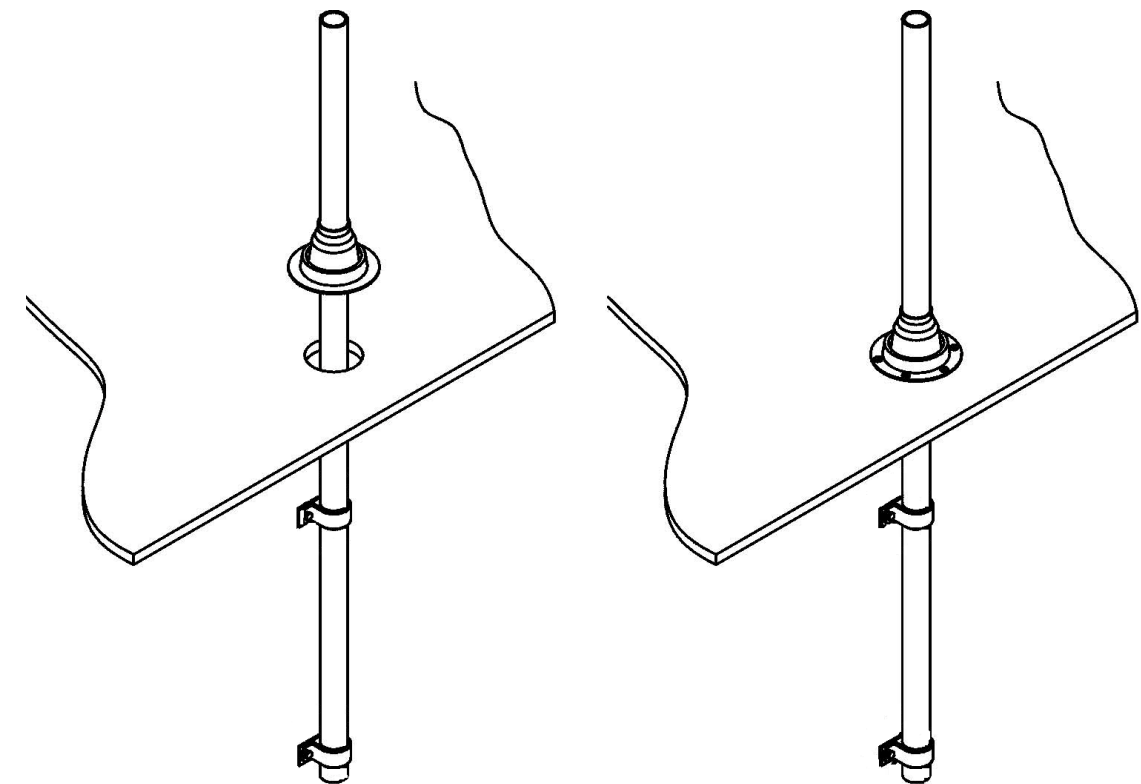

Seal the layers of roofing material to each other with a silicone caulk or sealant so that moisture is prevented from penetrating through to the wood. Apply a generous amount of sealant to the base of the seal. Slide the seal the rest of the way down onto the roof and locate it so that the base is centered over the hole.

The mast should be raised or lowered until it is in the desired position (twisting as you push or pull will help the mast to slide).

Attic Mounting

On some structures it may be desirable to mount the turbine mounting pole(s) from inside the attic. This involves mounting the isolators and clamps inside the attic and boring a hole through the roof for the pole. An optional roof seal is available to seal the pole to the roof and still allow the necessary freedom of movement for the pole to be properly isolated. This type of installation requires mounting boards for the mounting of the roof mount kit.

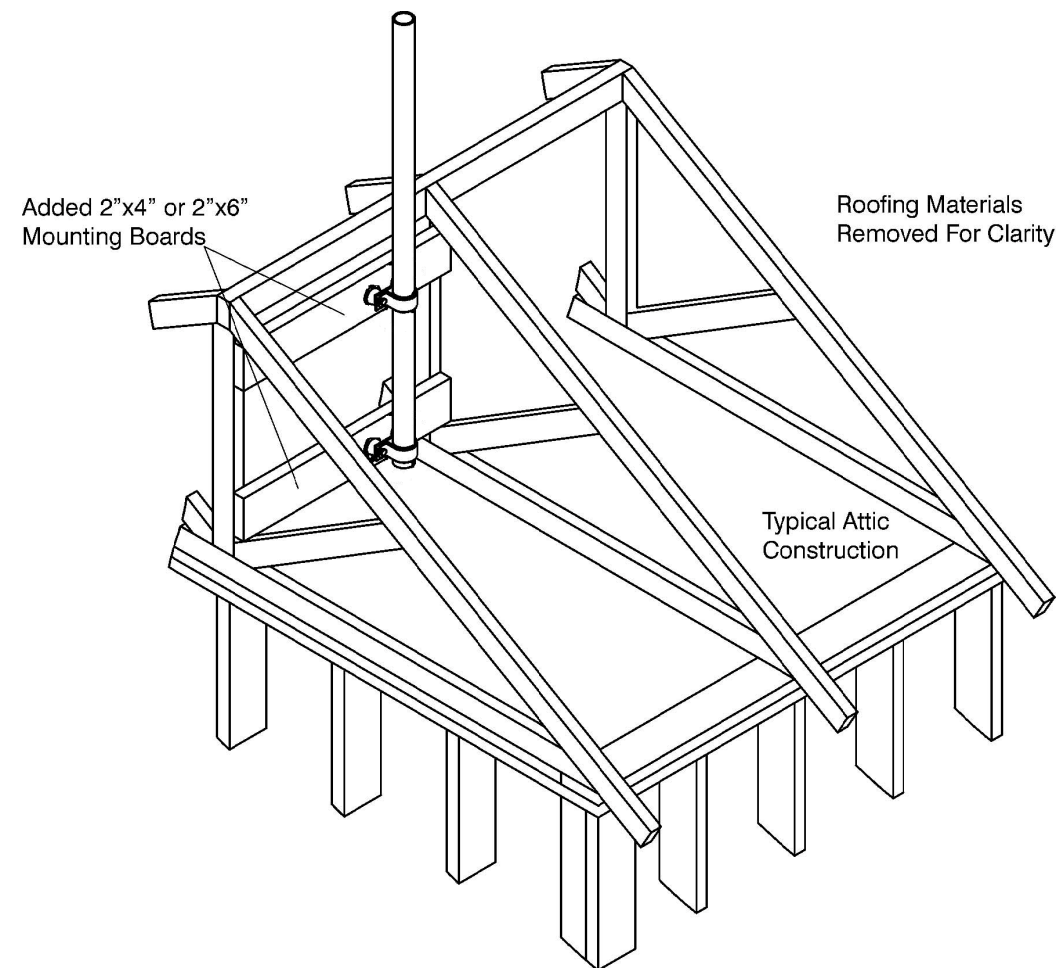

Mounting Through a Roof or Roof Overhang

Site Selection

The Roof Mount Kit allows the pole for your **AIR** wind turbine to be mounted to the wall or roof truss of a structure and extend above its roofline. This provides the simplest mounting method available for installing your **AIR** wind turbine. The highest and most open site for mounting of your wind turbine will give the best performance. At a minimum the turbine must be mounted high enough for the blades to clear all obstructions by at least one foot. Avoid mounting the turbine near tall trees or other structures, which may block the wind. Be sure that it is well above overhead wires, tree branches or any other obstacles. In some cases mounting your turbine directly above the crest of your structure can actually increase the amount of wind energy seen by the turbine by directing air up toward it.

Avoid mounting the turbine on the downwind side of your structure where wind turbulence may become a factor in turbine performance. For more complete information regarding the best positioning of your turbine, refer to your **AIR** owner's manual.

If you are planning to mount more than one turbine to your structure the turbines should be spaced at least ten feet (3 meters) apart. This will help to reduce the effects of one turbine on another in respect to airflow. Avoid mounting turbines in-line with prevailing winds.

The distance between the upper and lower mounts is also important. The height of the turbine above the upper mount should not exceed two times the distance between the upper and lower mounts, so that if the mounts are three feet apart, the turbine should not be more than six feet above the upper mount (see diagram). The maximum turbine mounting height above the upper mount should not exceed eight feet (2.5 m).

Once the location and pole height have been determined, the structure should be examined for the strongest and most rigid mounting points. On a wood framed structure this would be directly over a wall stud where the isolators can be mounted very solidly. A better option is to add mounting boards for each of the isolators, and fasten them securely to two or more studs of the structure. Several three-inch (75 mm) long lag bolts or large screws into each stud will usually do the job.

On a brick, concrete or block walled structure, there are no studs in the walls and the exact location of the mounting points is less critical.

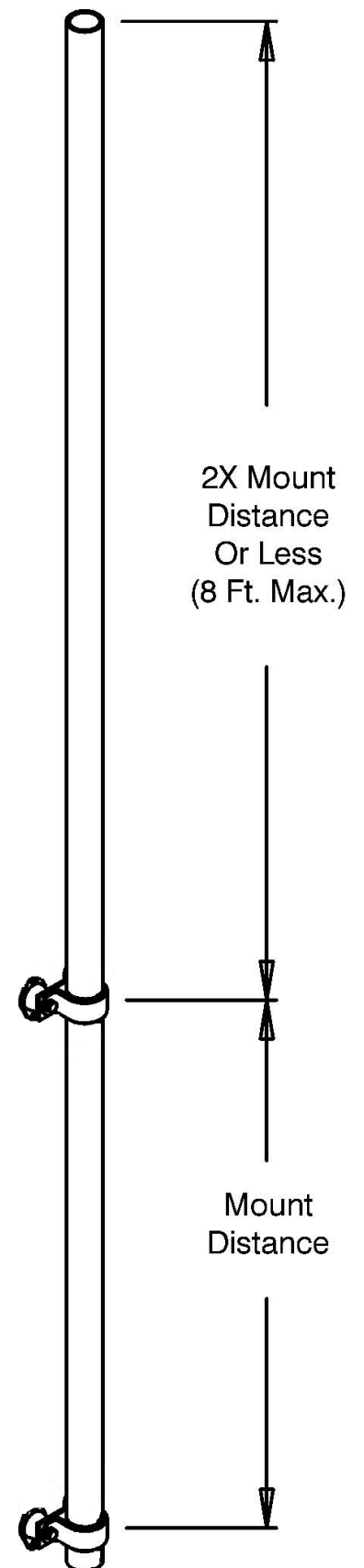

In all cases the system should be mounted as solidly as possible to the most rigid part of the structure.

An option on some structures is to mount the pole from inside the attic (refer to “Attic Mounting” on page 8). The pole will then protrude through a hole in the roof (optional roof seals are available for this purpose). For this type of installation mounting two 2x4 or 2x6 boards across the rafters or trusses is recommended for the mounting of the isolators (see drawing on page 8). If the pole is mounted and there is some time delay before the turbine is installed, be sure to cover or plug the top of the pole so that moisture does not enter through it.

Pole and Hardware Selection

The pole for mounting an “AIR” wind turbine must be 1.875” to 1.9” (48 mm) outside diameter. This is the actual diameter of 1 ½” schedule 20 or 40 pipe. The material should be Aluminum of at least 1/8” wall thickness, or steel of at least 1/16” wall thickness. The kit is designed for use with .065 in. (1.65 mm) wall thickness fence post tubing, which is lightweight and economical. If heavier pipe must be used, the total pipe length must be kept under 8 feet or additional isolators will be needed to help support the extra weight.

A good source of pipe or tubing for the pole is your local fence supply company, where this tubing is commonly used for chain link fence posts. If you determine the length of tubing needed for your application ahead of time, the fence supply company will usually sell what you need cut to length. Make sure the ends are smooth and free of burrs so that the turbine wires can not be damaged or cut by the tubing. This may require de-burring the tubing with a file after it is cut.

The hardware you will need to mount your kit will depend on the type and thickness of siding used on your structure. For a typical wood frame structure with 1/2” (13 mm) siding, it is recommended that mounting boards over at least two studs be installed using either 3” (75 mm) long lag bolts and washers or wood screws fastening the boards to each stud. 3/8” bolts (lag or through) with washers should then be used to mount the isolators to the mounting boards.

If only a single wall stud is available for mounting, plywood blocks at least 1” (25 mm) thick and 12” (300 mm) square should be mounted to the stud with at least two 3” (75mm) long x 3/8” diameter lag bolts and washers. The isolators should be mounted to the blocks with 3/8” bolts (lag or through) and washers. In the case of brick or concrete walls, expansion bolts may be used to attach the pole to the wall, although bolting through the wall is preferred.

Site Preparation

It is recommended that 2x4 or 2x6 mounting boards be used. This option allows the most flexibility as to where the turbine will be mounted and gives the best mounting surface. They should be mounted directly to wall studs at both of their ends and to each stud available along their length. Once installed, the roof mount kit can be placed

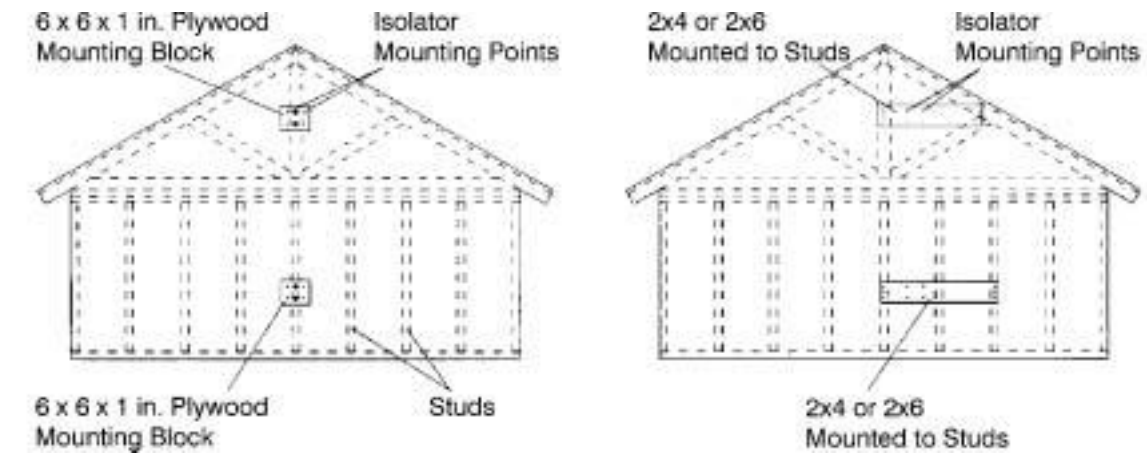

anywhere along their length.

If only a single wall stud is available for mounting, plywood blocks at least 1” (25 mm) thick and 12” (300 mm) square should be centered on the stud and mounted with 3” (75mm) long lag bolts and washers. The mounts should be centered on these blocks.

Assemble a mount with its base plate and two isolators. Hold the assembled unit in the desired position for the upper mount and mark the hole locations for the 2 isolator mounting. Repeat this process for the lower mount location using a plumb-bob to assure vertical alignment. Drill holes appropriate for the hardware to be used on these marks.

Pole Mounting

Mount the isolators to the holes, which were drilled in “Site Preparation”, on page 7.

Slip the plastic clamp inserts onto your pole and slide them into the approximate mounting locations on the pole. Make sure the ends of the pole are smooth and burr free before mounting so that the turbine wires cannot be damaged or cut by the end of the tubing. This may require dressing the tubing with a file after it is cut.

Assemble the clamp straps, insert, and base plate together and place a bolt with lock washer through each hole (see part list drawing). Screw the bolts into the appropriate isolators until finger tight. Repeat this procedure for the second mount.